

SIAT

MAILLIS

SR20 Semi-Automatic Carton Sealers



STRONG DESIGN
Solid H frame structure



EASY MAINTENANCE
Fast-removable top taping head

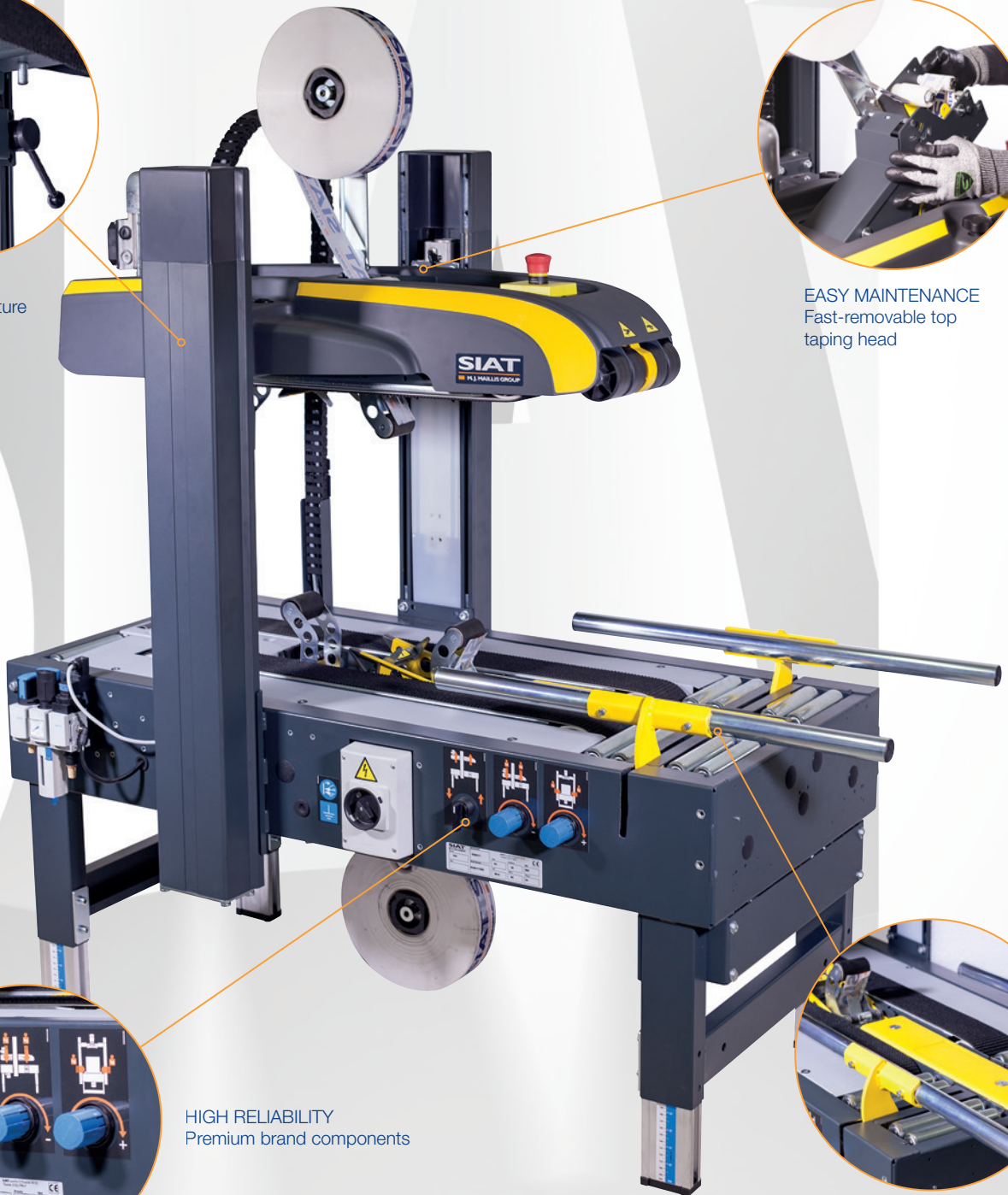

HIGH RELIABILITY
Premium brand components



PERFECT CONTROL
Thanks to the 4 belts and the random adjustment on the box size

CE

for more details:



SR20

The semi-automatic case sealer **SR20** represents the ideal solution when your packaging line processes boxes with different dimension. Thanks to the 4 belts box control, the sealing process is always guaranteed without jams, also in case of overstuffed and empty boxes. The pneumatic system allows a fast adaptation to a large range of box dimensions. The robust dual masts frame and the branded components make the **SR20** ready for round-the-clock applications. The historical SIAT machines reliability is always guaranteed! The fast-removable taping head, the easy access to the motors and the clear cable management allow an efficient check of the machine, facilitating maintenance operations.

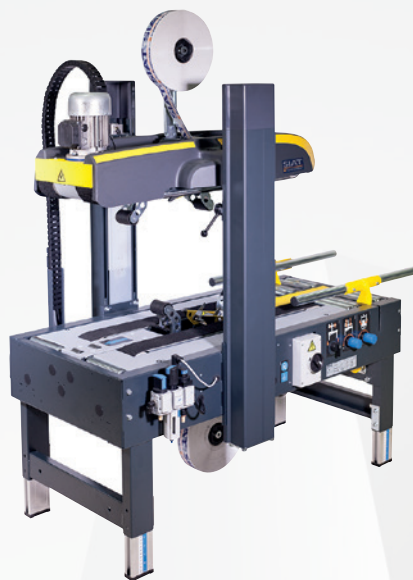

other languages: www.siat.com



> **Machine dimensions**
Dimensioni macchina
Machinmessungen
Dimensions de la machine
Dimensiones de máquina

Packaging size / weight			LxWxH
> SR20	170	190	130x78x115

> **SR20**

	Min.	Max
L	1240	-
L1	1395	-
W	740	-
H	1265	1605
cbh	485	825
AS 77	cbh +110	cbh +110
AS 80	cbh +160	cbh +160

> **Box dimensions**
Dimensioni delle scatole
Kartonabmessungen
Dimensions des boîtes
Dimensiones de cajas

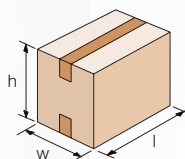

> **SR20**

	K11R std. / K12R on demand	
	Min.	Max
l	150	∞
w*	140 / 170	500
h	100	500

> **Production capacity**
Capacità di produzione
Produktionskapazität
Capacité de production
Capacidad de producción

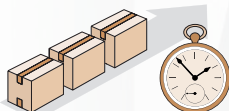

> **SR20**

	Bph
Max pcs.*	900

* Always based on shorter manageable box

> **Air consumption**
Consumo aria
Druckluftverbrauch
Consommation air comprimé
Consumo de aire

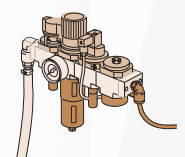

> **SR20**

	NL.
Cycle	9

from 5,5 bar to 7 bar

> **Standard voltage**
Voltage standard
Standardspannung
Tension standard
Voltage estándar

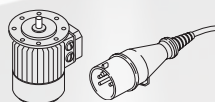

> **SR20**

380/415V - 50Hz - 3P	
Amps	1,08
Power kW	0,26
Phase	3Ph + N + PE

> **SR20**

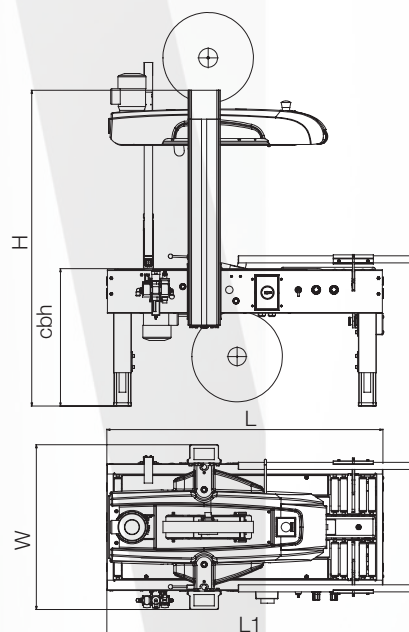

> **Taping units**
Unità nastranti
Verschliesseinheiten
Unités enrubanneuses
Unidades de precinto

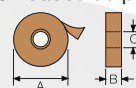

	K11R/ K12R
	mm
A	410 Max
B	50 / 75
C	76

> **Optionals**
Accessori
Zubehör
Accessories
Accesorios

> **AS80**
Higher legs
Set gambe più alte
Höhere Stützen
Pieds plus hauts
Patatas más altas

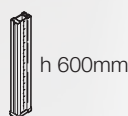

> **AS77**
Casters
Set ruote
Rädchen
Roulettes
Ruedas

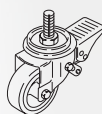

> **RG**
Roller conveyor
Piani a rulli
Rollenbahnen
Plans à rouleaux
Rodillos libres



> **GTL - GTR**
Extendable conveyor
Rulliera estensibile
Ausziehbare rollenbahnen
Convoyeur extensible
Rodillos extensibles

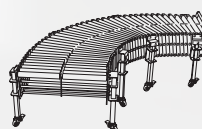

> **K-125 / K-250**
Inkjet printer
Stampante ad inchiostro
Tintenstrahldrucker
Marqueur à jet d'encre
Impresora de inyección de tinta

