

Ideal for Shelf Ready Packaging, stacks of laundry and more!

The Bandall TRB series conveys products into the banding arch using motorised conveyor belts. These conveyor belts can be low friction or high friction, depending on the type of product to be banded. The TRB conveyor belts are available in various lengths and widths.

Fully automatic and budget-friendly banding

This equipment is ideal for easy and budget-friendly banding of trays, multi-packs or stacks of products. Sturdy, reliable and efficient, often used for products with a flat and rigid base.

Product detection

The product to be banded is transferred from an existing conveying system and conveyed into the arch. The conveyor stops when the product has been detected by a sensor and the product is automatically banded. If required, a second adjustable sensor can be added for double banding.

When banding is complete, the conveyor restarts and the banded product is conveyed out of the arch. The speed of the two conveyor lines can be set individually. On the in-feed side the installation has two product guides which accurately position the product to be banded before it enters the banding arch.

Immediate benefits

- ✓ fully automatic in and out feed
- ✓ immense savings in packaging material
- ✓ taping, gluing and sealing machines are often rendered redundant
- ✓ major savings in energy costs
- ✓ supplied with multi connector for signal exchange
- ✓ limited space required
- ✓ easily adjustable and portable



bandall[®]
The standard in banding

BANDING
TOGETHER



TRB-series; easy to operate and to add to

The Bandall TRB is a successful innovation based on the patented Bandall banding equipment. With a modular construction, the TRB can easily be extended with additional functions, such as presses and printers. The TRB is also available in stainless steel.

Bandall TRB Series features

- ✓ ideal for 'end of line' use
- ✓ fully adjustable belt tension
- ✓ several bands per product or tray possible
- ✓ lowest cost of ownership



- ✓ **Reliable**
- ✓ **Efficient**
- ✓ **Damage-free**
- ✓ **Flexible**

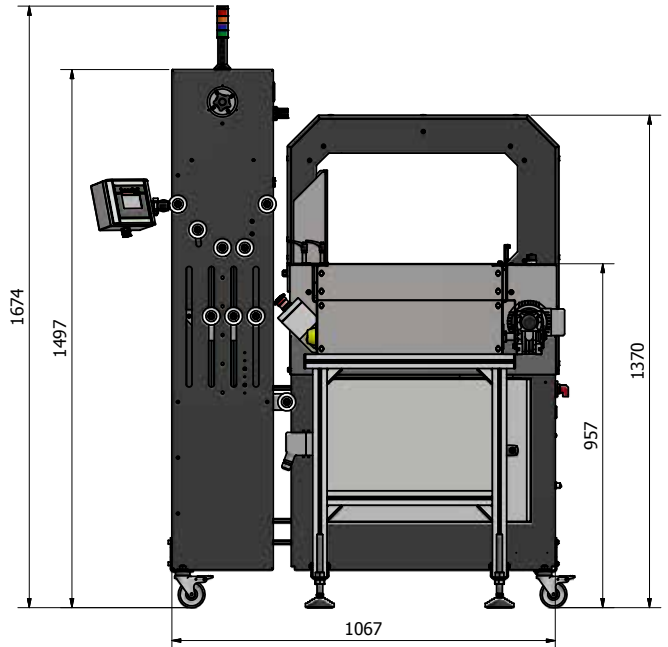
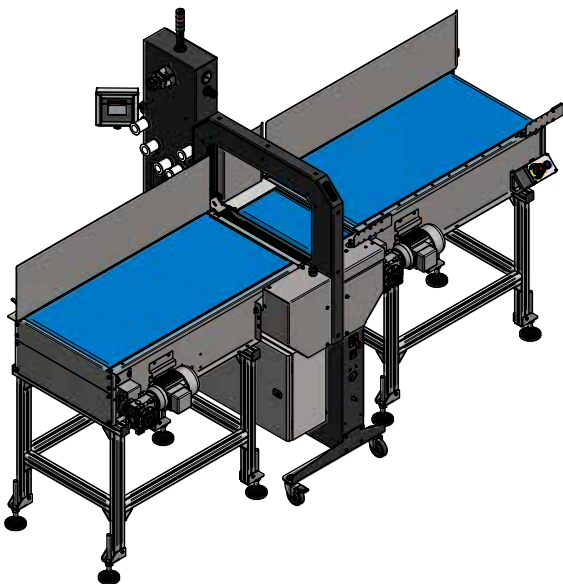

The TRB series is available for processing banding in many widths from 20 to 100 mm and with a wide choice of arch sizes. ▲

Bandall

Damzigt 45 3454 PS De Meern - Utrecht The Netherlands

T +31 (0)348 431520 F +31 (0)348 431480 E info@bandall.com I www.bandall.com

